

Please, read this manual
carefully before use!

Owner's Manual



Kinetic log splitter

KS 8TKE 52/35

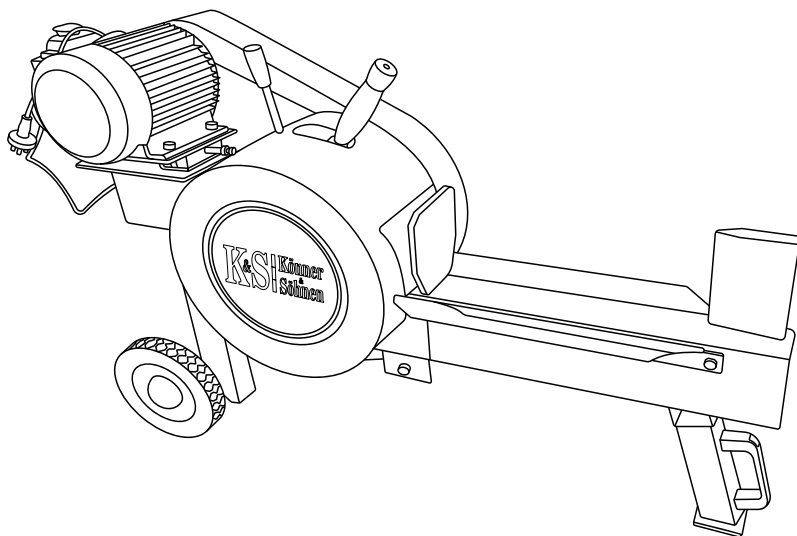



Thank you for your purchase of **Könner & Söhnen** products. This manual contains a brief description of safety, use and debugging. More information can be found on the official manufacturer's website in the support section: ks-power.de/betriebsanleitungen.

You can also go to the support section and download the full version of the manual by scanning the QR code, or on the website of the official importer of Könner & Söhnen products: www.ks-power.de/en.



We care about the environment, therefore, we consider it expedient to save paper and leave in print a short description of the most important sections.



Be sure to read the full version of the manual before getting started!



Manufacturer reserves the right to make alterations into the generators, which may not be reflected in this manual. Pictures and photos of the product may vary from its actual appearance. At the end of this manual, You may find contact information which you are free to use in case of any issues occurrence.

All data, specified in this operation manual is the most up to date for the moment of its publishing. The current list of service centers you can find at the website of official importer: www.ks-power.de/en.



ATTENTION – DANGER!



Failure to follow the recommendations marked with this sign may lead to serious injury or death of the operator or third parties.



IMPORTANT!



Useful information while operating the machine.

Safety symbols and description of inscriptions can be found in the full web version.

SAFETY INFORMATION

1



WARNING!



Please, read this manual carefully before use!

PROTECTING YOURSELF AND THOSE AROUND YOU

1.2



WARNING!



This is a high-powered machine, with moving parts operating with high energy. You must operate the machine safely. Unsafe operation can create a number of hazards for you, as well as anyone else in the nearby area.

Always take the following precautions when using this machine:

- Keep in mind that the operator or user is responsible for accidents or hazards occurring to other people, their property, and themselves.
- Always wear protective goggles or safety glasses with side shields while using the Log Splitter to protect your eyes from possible thrown debris.
- Avoid wearing loose clothing or jewelry, which can catch on moving parts.
- We recommend wearing gloves while using the Log Splitter.
- Wear shoes with non-slip treads when using your Log Splitter. Do not use the machine while barefoot or wearing open toed sandals.
- Wear long pants while operating the Log Splitter.

- Keep bystanders at least 50 feet away from your work area at all times. Stop the motor when another person or pet approaches.
- Never allow children to operate the Log Splitter.

SAFETY WITH ELECTRIC - POWERED MACHINES

1.3



WARNING!



Never overlook the hazards of electricity.

Always follow these precautions:

- Never open the switch box or motor cover. Never attempt any electrical repairs yourself. In if doubt, consult a qualified electrician, or contact your local dealer for help or informations.
- Never use an extension cord that is not rated for outdoor use.
- Never operate the Log Splitter if there is an electrical hazard present.
- Never operate the Log Splitter in wet conditions and always store under cover.
- Never operate the Log Splitter with a damaged electrical cord or damaged extension cord.
- Never pull on the electrical cord to move the machine.
- Always grasp the electrical cord plug when unplugging the cord from the outlet; never pull the plug out by the cord. Make sure your fingers do not touch the metal prongs when plugging or unplugging.
- Never operate the Log Splitter unless the electrical cord is plug
- If you are using an extension cord, keep the connection between the electrical cord and the extension cord well away from any water.
- Never use an extension cord longer than 25 feet and smaller than 2 mm² in diameter, the cord will produce a voltage drop that will prevent the motor from supplying full power and may cause damage to the motor. Use of a smaller diameter extension cord could result in melting of the insulation or even create a fire.
- Always keep the electrical cord and/or extension cord away from excessive heat, oil, and sharp objects.



WARNING!



Operating this Log Splitter safely is necessary to prevent or minimize the risk of death or serious injury. Unsafe operation can create a number of hazards for you.

Always take the following precautions when operating this Log Splitter:

- The machine is designed to split logs. Do not use it for any other purpose.
- Never operate your unit on a slippery, wet, muddy, or icy surface.
- Exercise caution to avoid slipping or falling.
- Never, under any conditions, remove, bend, cut, fit, weld, or otherwise alter standard parts on the Log Splitter. This includes all shields and guards. Modifications to your machine could cause personal injuries and property damage and will void your warranty.
- Allow only one person to operate the Log Splitter at any time. This includes placing the log on the beam.
- If the machine should start making an unusual noise or vibration, shut off the Motor, Unplug the Power Cord, wait five minutes for machine to cool down then inspect for damage. Vibration is generally a warning of trouble. Check for damaged parts and clean, repair and replace as necessary.
- Never tamper with safety devices. Check their proper operation regularly.
- Before performing any maintenance or inspection procedure on the Log Splitter, shut off the Motor, unplug the Power Cord and wait five minutes for machine to cool down.
- Never allow people who are unfamiliar with these instructions to use the Log Splitter.
- Never overload or attempt to split logs beyond the recommendations listed in this manual.
- Never operate the machine when under the influence of alcohol, drugs, or medication.
- Use the machine only in daylight.
- Keep all nuts and bolts tight and keep the equipment in good operating condition.

Model	KS 8TKE 52/35
Voltage	230 V
Frequency	50 Hz
Engine power	2000 W
Force	8 ton
Engine type	electric
Engine model	KS ECO 2100
Max. Length	520 mm
Max. Diameter	350 mm
Cycle time	~ 2 sek.
Operating position	horizontal
Flywheel speed	400 U/min
Cable length	1.7 m
Electric motor winding	copper
Wheels	8"
Gross dimensions (LxWxH)	1270x340x780 mm
Gross weight	130 kg
Protection class	IP54M



NOTICE



The diameter of the log is not the only factor that determines how easy it is to split. A small log may be difficult to split if it has knots or is a particularly hard wood.

Connect the mains lead to a standard 230V±10% (50Hz ±1Hz) electrical supply which has under-voltage, over-voltage and over-current protection devices as well as a residual current device (RCD) with a maximum residual current rated at 0.03A.

KINETIC LOG SPLITTER CONTROLS AND FEATURES

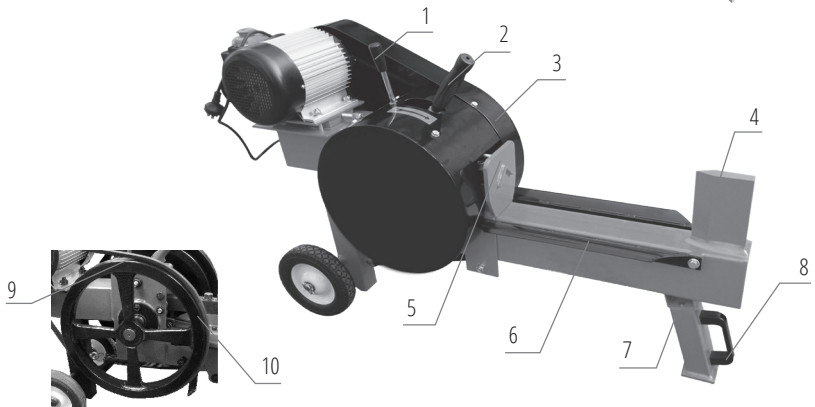

1. Safety Level
2. Engagement Handle
3. Belt Guard
4. Splitting Wedge
5. Ram

6. Cradle
7. Frame Stand
8. Handle
9. Belt
10. Flywheel

STARTING THE MOTOR

1. Position your Log Splitter on a flat, dry surface and chock the Wheels or screw down the Frame Stand to prevent the Splitter from moving during use.
2. Make sure the Log Splitter is plugged into a properly grounded protected outlet.
3. Push the green button (Fig. 1).

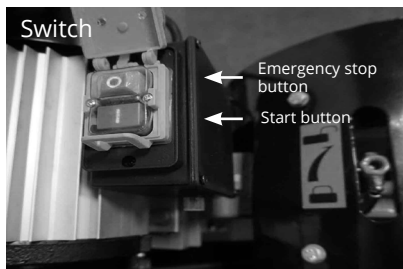

Fig. 1

STOPPING THE MOTOR

Push the emergency stop or red button to shut the Motor off (Figure 1).



NOTE



Unplug the Power Cord when not using the Splitter.

SPLITTING LOGS

5



NOTICE



The kinetic log splitter operates differently than a hydraulic splitter. Not operating the machine properly will result in damage to the machine.



Fig. 2



Fig. 3



Fig. 4

All logs should be no longer than rated. Refer to the following photos for the correct and incorrect methods of splitting logs. Never split a log using an incorrect or unsafe method.

- Do not place your hands on the ends of the log when loading the Log Splitter. This is a very UNSAFE method and could result in injury to your hands (Figure 3).
- Do not reach or step across the beam while the Log Splitter is running. This is a very UNSAFE method which could cause personal injury or even death.
- Never attempt to split wood across the grain (Fig.3). The Log Splitter was not designed for cross-grain splitting. Doing so could damage the Log Splitter and may cause personal injury.
- Make sure both ends of the log you are splitting are cut as square as possible (Fig.4). This will prevent the log from sliding out of position while under pressure.

Always follow these notices:

- Do not be timid. A rapid movement of the Engagement Handle is necessary for the Rack and Pinion to engage and disengage fully without damage.
- The Engagement Handle should never be stopped in any location between the fully forward or fully backward positions.

• Do not hold the Handle in the forward position when the Ram stops moving forward. Always pull the Engagement Handle RAPIDLY to the back (Auto-Retract) position as soon as the Log is split or when the Ram is at the end of the stroke or when the Ram stops moving forward due to a tough log.

1. Place the log on the Log Splitter. Grasp the log on the sides near the middle of the block (Fig. 5). Center the log, side-to-side, on the rail of the Log Splitter. Do not place the log tightly to the cutting knife. The recommended distance from the cutting knife is 4-5 cm.

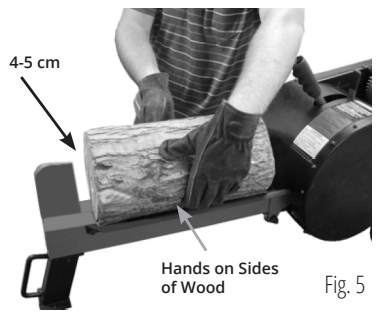

Fig. 5

CAUTION!   **The engagement Handle must be held fully in the Split Position against the hard stop when splitting. Failure to do so may result in kickback of the Handle.**

2. With one hand, actuate and hold the safety lever towards you, then RAPIDLY actuate the Engagement Handle fully towards the Motor until it contacts the hard stop and hold firmly until the Log is split (Fig. 6).

3. IMMEDIATELY AFTER the log is split, actuate and hold the Engagement Handle to the Auto-Retract position to allow the Ram to return. If the Ram stops before the end of the stroke while splitting a tough log, quickly actuate the Engagement Handle back to the Auto-Retract position.



Fig. 6

If the Ram stops before the end of the stroke while splitting a tough Log, quickly actuate the Engagement Handle back to the Auto-Retract position. Let the Ram return and allow the Flywheels to gain momentum for another full power split.

MAINTAINING THE KINETIC LOG SPLITTER 6

WARNING!   **Before performing any maintenance procedure or inspection, stop the electric motor, wait five minutes to allow all parts to cool. Disconnect the power cord from the source of Electricity.**

LUBRICATION

WARNING!   **All Bearings of your Splitter are sealed units and should have sufficient lubricant to last the life of your machine with normal use.**

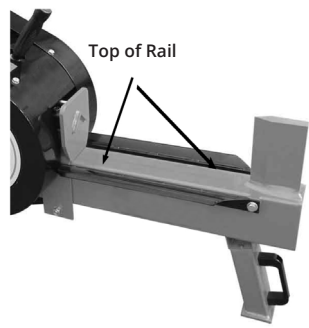

RAIL MAINTENANCE

Between each use of the LOG SPLITTER, we recommend removing any debris caught on the Rail or Ram and applying a rust preventative (Fluid Film or equivalent) to any bare metal areas on the top of the Rail (Fig. 7). This will assure the smoothest return action of the Ram.

GREASING THE RACK

Between each use of the LOG SPLITTER, we recommend removing any debris caught on the Rail or Ram and applying a rust preventative (Fluid Film or equivalent) to any bare metal areas on the top of the Rail (Fig. 7). This will assure the smoothest return action of the Ram.

 **NOTE**  **It is important to grease the Rack every 5 hours for proper operation.**

Tools and Supplies needed:

- General Purpose Grease
 - Clean Rags
 - 13mm Wrench
1. Use a 13mm wrench to remove the Guard Screws that secure the flywheel Guard (Fig. 8).
 2. Remove the Guard Screws that secure the Flywheel and Belt Guard.
 3. Disconnect the return spring.
 4. Pull the Rack out and grease the Rack Teeth, top side of the Rack and the Pinion (Fig. 9).
 5. Push the Rack back in and reinstall the Return Spring when finished greasing.
 6. Reinstall the Guards.

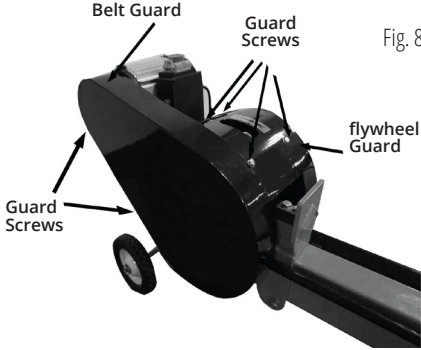

Fig. 8

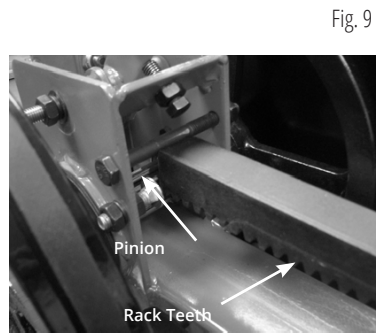

Fig. 9

REGULAR MAINTENANCE CHECKLIST 7

Folgen Sie allen Anweisungen dieser Betriebsanleitung! Die aktuelle Liste der Servicezentren finden Sie auf der offiziellen Website des autorisierten Importeurs: www.ks-power.de

PROCEDURE	Before each use	Every 5 hours	Every 25 hours
Check General Equipment Condition	✓		
Perform Rail Maintenance	✓		
Check Belt	✓		
Check the condition of the electrical cord.	✓		
Grease Rack		✓	
Clean Motor Exterior and Cooling Fins			✓

| *Potential faults and troubleshooting methods can be found in the full version of the manual.*

WARRANTY SERVICE TERMS**8**

The international manufacturer warranty is 1 year. The warranty period starts from the date of purchase. In cases when warranty period is longer than 1 year according to local legislation please contact your local dealer. The Seller which sells the product is responsible for granting the warranty. Please contact the Seller for warranty. Within the warranty period, if the product fails because of defects in the production process, it will be exchanged on the same product or repaired.

The warranty card should be kept throughout the warranty period. In case of warranty card loss, a second one will not be provided. The customer must provide the warranty card and buyer`s check during request for repair or exchange. Otherwise, the warranty service will not be provided. The warranty card, attached to the product during sale, should be correctly and fully completed by the retailer and customer, signed and stamped. In other cases, warranty is not considered as valid.

Provide clean product to the service center. Parts, that must be replaced, are the property of the service center.



EC Declaration of Conformity

Nr. 086

The following products have been tested by us with the listed standards and found in compliance with the European Community Machinery Directive 2006/42/EC, Low Voltage Directive 2014/35/EC, Electromagnetic compatibility Directive (EMC) 2014/30/EC, Noise Directive 2000/14/EC.

Manufacturer: DIMAX INTERNATIONAL GmbH
Address: Hauptstr. 134, 51143 Cologne, Germany

Product: Electric log splitter "Könner & Söhnen"

Type / Model: KS 7THE 52/30, KS 8TKE 52/55

The statement is based on a single evaluation of above mentioned products. It does not imply an assessment of the whole production and does not permit the use of the test lab. logo. The manufacturer should ensure that all product in series production are in conformity with the product sample detailed in this report. The applicant should hold the whole technical report at disposal of the competent all the right.

Applied EC Directives: 2006/42/EC Machinery Directive
2014/30/EU Electromagnetic compatibility Directive (EMC)
2014/35/ EU Low Voltage
2000/14/EC Noise Directive

Applied Standards: EN ISO 12100:2010
EN 60204-1:2018
EN 609-1:2017
EN 55014-1:2017
EN 55014-2:1997/A2:2008
EN 61000-3-2:2014
EN 61000-3-3:2013

2000/14/EC_2005/88/EC Annex VI

For model KS 7THE 52/30, KS 8TKE 52/35 noise guaranteed $L_{WA} = 97$ dB (A).



19

Issued Date: 2020-10-06
Place of issue: Warsaw city
Technical expert: Homenco A.

DIMAX
International
GmbH

Steuer-Nr.: 103 5722 2493
USt-Id-Nr.: DE296177274

We DIMAX INTERNATIONAL GmbH hereby declare that specified above conforms covering European Parliament and Council Directives, 2006/42/EC of 17 May 2006 Machinery Directive, 2014/35/EC Low Voltage Directive of 26 February 2014, Electromagnetic compatibility Directive (EMC) 2014/30/EC of 26 February 2014, Noise Directive 2000/14/EC of 8 May 2000. The CE mark above can be used under the responsibility of manufacturer. After completion of an EC declaration of Conformity and compliance with all relevant EC directives.

CONTACTS

Deutschland:

DIMAX International GmbH
Deutschland, Hauptstr. 134,
51143 Köln,
www.ks-power.de

Ihre Bestellungen

orders@dimaxgroup.de

Kundendienst, technische Fragen und Unterstützung

support@dimaxgroup.de

Garantie, Reparatur und Service

service@dimaxgroup.de

Sonstiges

info@dimaxgroup.de

Polska:

DIMAX International
Poland Sp.z o.o.

Polen, Warczawska, 306B
05-082 Stare Babice,

www.ks-power.pl
info.pl@dimaxgroup.de

Україна:

ТОВ «Техно Трейд КС», вул.
Електротехнічна 47, 02222,
м. Київ, Україна

www.ks-power.com.ua
sales@ks-power.com.ua

Россия:

ТД «Рус Энержи К&С» 129090,
г.Москва, проспект Мира,
д.19, стр.1, эт.1, пом.1,
комн.66, офис 99В

www.ks-power.ru
info@ks-power.ru