

Please, read this manual
carefully before use!

Owner's Manual



TRADITIONELLE DEUTSCHE QUALITÄT

K&S
Könner
&
Söhnen

Electric Horizontal Log Splitter

KS 7THE 52/30

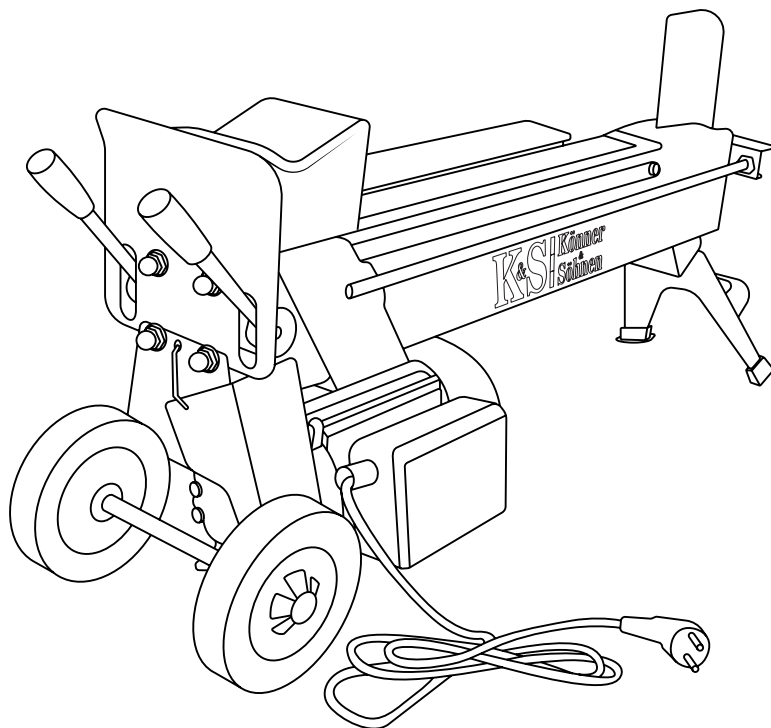



Thank you for your purchase of **Könner & Söhnen** products. This manual contains a brief description of safety, use and debugging. More information can be found on the official manufacturer's website in the support section: ks-power.de/betriebsanleitungen.

You can also go to the support section and download the full version of the manual by scanning the QR code, or on the website of the official importer of Könner & Söhnen products: www.ks-power.de/en.



We care about the environment, therefore, we consider it expedient to save paper and leave in print a short description of the most important sections.



Be sure to read the full version of the manual before getting started!



Manufacturer reserves the right to make alterations into the generators, which may not be reflected in this manual. Pictures and photos of the product may vary from its actual appearance. At the end of this manual, You may find contact information which you are free to use in case of any issues occurrence.

All data, specified in this operation manual is the most up to date for the moment of its publishing. The current list of service centers you can find at the website of official importer: www.ks-power.de/en.



ATTENTION – DANGER!



Failure to follow the recommendations marked with this sign may lead to serious injury or death of the operator or third parties.



IMPORTANT!



Useful information while operating the machine.

Safety symbols and description of inscriptions can be found in the full web version.

SAFETY INFORMATION

1



WARNING!



Read and understand the owner's manual and labels affixed to the log splitter. Learn its application and limitations as well as the specific potential hazards.

- Check your log splitter before use. Keep the guards in place and in working order. Check that any keys, tools or adjusting wrenches are removed from the tool area before switching on. Replace damaged, missing or failed parts immediately. Check that the electric circuit is adequately protected and that it corresponds with the power, voltage and frequency of the motor. Check that there is an earth connection, and a regulation differential switch upstream. Never open the pushbutton box on the motor – should this be necessary consult a qualified electrician. Make sure your fingers do not touch the plug's metal prongs when plugging in or unplugging the log splitter. If you need to use an extension lead, ensure that it is no longer than 10 metres and its cross-section is no less than 2.5 mm² to allow sufficient current flow to the motor. Use lockable and adequately insulated connections. Connections must be made with protected material suitable for outdoor use. When unpacking the log splitter please ensure that you remove the wooden packing block and it's securing strap from under the motor.

- Do NOT operate the log splitter whilst under the influence of drugs, alcohol or any medication that could affect your ability to use the apparatus correctly.

- Dress appropriately – do NOT wear loose clothing, ties, jewellery or anything that could be caught in the moving parts. Protective, electrically non-conductive gloves and strong footwear are recommended.



- Cover or tie back long hair to prevent it getting caught in the machinery. ALWAYS wear safety goggles and ear protectors.



- Never stand on the log splitter. Keep proper footing and balance at all times. Ensure that the ground beneath the log splitter is not slippery. Do not store anything above or near the log splitter which would necessitate standing on the machine to reach it.

- The log splitter must always be operated by one person ONLY. Other people should keep a safe distance from the work area when the log splitter is in operation or switched on. Keep children away from the log splitter at all times. Store in a locked workshop and disconnect master switches after use.



APPLICATION CONDITIONS OF THE LOG SPLITTER

2

- Put the log splitter on a 60-70cm high, stable, flat and level work bench where there is plenty of room. If possible use a special log splitter stand. Bolt the log splitter to the work surface if it tends to walk, slip or slide. Keep your work area clean and well-lit. Cluttered areas invite injuries. Do NOT use the log splitter in wet or damp areas or expose it to rain. Do NOT use in an area where fumes from paint, solvents or inflammable liquid pose a potential hazard.



- Make sure there are no nails or foreign objects in the logs to be split. The ends of the logs must be cut square. Branches must be cut off flush with the trunk.



- Always pay full attention to the movement of the log pusher.

- Keep your hands away from splits and cracks which open up in the wood – they may close suddenly and cause injury. Do NOT attempt to remove jammed logs with your hands.



- The log splitter will do a better and safer job at its designed pressure/rate. Never try to split logs larger than those indicated in the specifications table. This could be dangerous and may damage the machine. Never leave the log splitter running unattended.



- Always pay full attention to the movement of the log pusher. Do not attempt to load the log on until the log pusher has stopped. Keep your hands away from all moving parts.

- Unplug when not in use, before making adjustments, changing parts, cleaning or working on the log splitter.

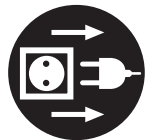

- Dispose of used oil responsibly. Take to an authorised collection point – refer to your local council for details. Do NOT discharge into drains, soil or water.

The log splitter is for domestic use. It is designed for operation under ambient temperatures between +5°C and 40°C and for installation at altitudes of no more than 1000m above MSL.

The surrounding humidity should be less than 50% at 40°C. It can be stored or transported under ambient temperatures between -25°C and 55°C.

Model	KS 7THE 52/30
Voltage	230 V
Frequency	50 Hz
Engine power	2000 W
Force	7 ton
Engine type	electric
Engine model	KS ECO 2100
Max. Length	520 mm
Max. Diameter	300 mm
Cycle time	~ 10 sek.
Operating position	horizontal
Cable length	1.85 m
Electric motor winding	copper
Hydraulic Oil Capacity	2,9 l
Wheels	6"
Gross dimensions (LxWxH)	980x270x520 mm
Gross weight	49 kg
Protection class	IP54M



NOTICE



The diameter of the log is not the only factor that determines how easy it is to split. A small log may be difficult to split if it has knots or is a particularly hard wood.

Connect the mains lead to a standard 230V±10% (50Hz ±1Hz) electrical supply which has under-voltage, over-voltage and over-current protection devices as well as a residual current device (RCD) with a maximum residual current rated at 0.03A.

MAIN OVERVIEW

4

Check these components according to the following list and Figure 1 below:

- A. Log Guiding Plates
- B. Log Pusher
- C. Operating Handle Assembly
- D. Wheel and Frame
- E. Oil Pump
- F. Electrical Motor Switch
- G. Electrical Motor Assembly
- H. Supporting Feet
- I. Main Body
- J. Splitting Wedge

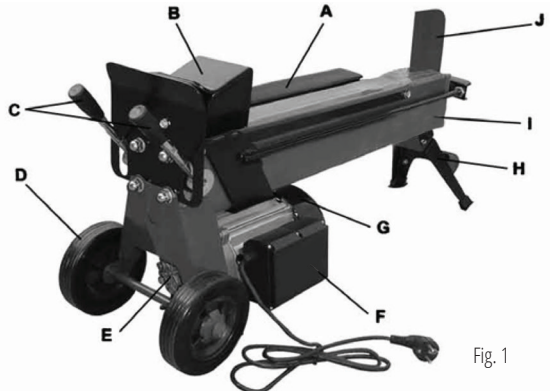

Fig. 1



WARNING!



Log splitter is supplied without the hydraulic oil. Please don't start the engine without filling the sufficient amount of hydraulic oil.

1. Plan the work area before using the log splitter. Have the logs positioned where they can be easily reached.
 2. The log splitter accommodates logs up to 52 cm in length. The log splitter will work most efficiently on dry, seasoned logs.
 3. Position the log splitter securely on level ground or on a secure stand. If necessary stabilise the wheels to prevent the log splitter from moving during use. If using an extension cable, do so in a safe way to avoid damaging the cable or creating a hazard.
 4. Before operating the log splitter, the bleed screws (Fig 3) should be loosened by 3-4 turns to allow the air in and out of the oil tank. Re-tighten the screw when the work is complete or when moving the log splitter to avoid oil leaks.
 5. Always place logs firmly on the main body, lying flat against the log guide plates (Ref A on Fig1). Never attempt to split a log at an angle and make sure the logs will not twist or slip whilst being split.
- Ensure the splitting wedge (Ref J on Fig1) and the log pusher (Ref B on Fig1) will make contact with the log squarely at each end.
6. For reasons of safety the log splitter requires a two-handed operation. Switch on the electric motor using the green starting switch (Ref F on Fig1). Using both hands press down on both operating handles (Ref C on Fig1). The log splitter will compress the log, pushing against the splitting wedge. When the log is split release both handles – this will allow the log pusher to retract.

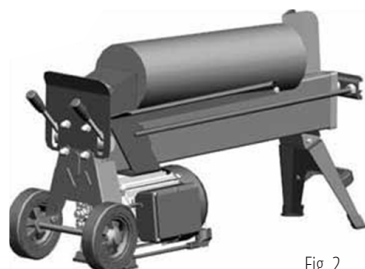

Fig. 2



Fig. 3

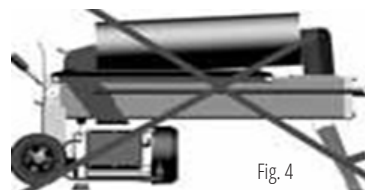

Fig. 4

Press the green button to stop the log splitter. Tighten the screw (Fig. 3) and unplug the appliance when operation is finished. Re-tighten the screw when the work is complete or when moving the log splitter to avoid oil leaks.



WARNING!



Never force the splitting of a log by sustaining the hydraulic pressure for more than 5 seconds. Try re-positioning the log on the splitter.

TO FREE A JAMMED LOG

6



Release both operating handles so that the log pusher is fully retracted. Insert a triangular wedge of wood under the log and activate the log pusher to push the wedge under the jammed log. Repeat this process using progressively larger wedges until the jammed log is freed.



WARNING!



Never hammer a jammed log or place your hands near the log when attempting to free a jammed log.

SHARPENING THE WEDGE AND CLEANING THE GUIDE RAIL

7

After using the log splitter for some time, sharpen the wedge using a fine tooth file and smooth any burrs or rough edges along the cutting edge.

Clean the guide rail regularly, especially when splitting wood that is rich in resin.

REPLACING HYDRAULIC OIL

8

Replace the hydraulic oil in the log splitter after every 150 hours of use. Take the following steps to replace the oil:

1. Make sure all moving parts are stopped and the log splitter is unplugged.
2. Unscrew the oil drain bolt.
3. Turn the log splitter onto the support leg side and hold over a 3 litre container to drain the oil into.
4. Turn the log splitter vertically to stand on its end with the motor underneath and the operating handles uppermost.
5. Fill with fresh hydraulic oil. As stated in the Specifications Table on page 5 the correct oil capacity is 2.9L.
6. Clean the surface of the dipstick, which is attached to the oil drain bolt, with a clean lint free cloth and put back into the tank to check the new level. Make sure the level of the refilled oil is just between the two grooves around the dipstick.
7. Clean the oil drain bolt before screwing it back. Make sure it is tightened to avoid leakage before placing the log splitter horizontally.



NOTICE



Periodically check the oil level to ensure it is between the two grooves on the dipstick. Refill when the oil reaches the lower level.

Use hydraulic oil ISO VG 22.

The following hydraulic oils or equivalent are recommended for the log splitter's hydraulic transmission system:

- SHELL Tellus 22
- ARAL Vitam GF22
- MOBIL DTE 11
- BP Energol HLP-HM22

WARRANTY SERVICE TERMS

9

The international manufacturer warranty is 1 year. The warranty period starts from the date of purchase. In cases when warranty period is longer than 1 year according to local legislation please contact your local dealer. The Seller which sells the product is responsible for granting the warranty. Please contact the Seller for warranty. Within the warranty period, if the product fails because of defects in the production process, it will be exchanged on the same product or repaired.

The warranty card should be kept throughout the warranty period. In case of warranty card loss, a second one will not be provided. The customer must provide the warranty card and buyer's check during request for repair or exchange. Otherwise, the warranty service will not be provided. The warranty card, attached to the product during sale, should be correctly and fully completed by the retailer and customer, signed and stamped. In other cases, warranty is not considered as valid.

Provide clean product to the service center. Parts, that must be replaced, are the property of the service center.

This manual compliance! You can find a list of service center addresses on the website of exclusive importer: www.ks-power.de/en



EC Declaration of Conformity

Nr. 086

The following products have been tested by us with the listed standards and found in compliance with the European Community Machinery Directive 2006/42/EC, Low Voltage Directive 2014/35/EC, Electromagnetic compatibility Directive (EMC) 2014/30/EC, Noise Directive 2000/14/EC.

Manufacturer: DIMAX INTERNATIONAL GmbH
Address: Hauptstr. 134, 51143 Cologne, Germany

Product: Electric log splitter "Könner & Söhnen"

Type / Model: KS 7THE 52/30, KS 8TKE 52/55

The statement is based on a single evaluation of above mentioned products. It does not imply an assessment of the whole production and does not permit the use of the test lab. logo. The manufacturer should ensure that all product in series production are in conformity with the product sample detailed in this report. The applicant should hold the whole technical report at disposal of the competent all the right.

Applied EC Directives: 2006/42/EC Machinery Directive
2014/30/EU Electromagnetic compatibility Directive (EMC)
2014/35/ EU Low Voltage
2000/14/EC Noise Directive

Applied Standards: EN ISO 12100:2010
EN 60204-1:2018
EN 609-1:2017
EN 55014-1:2017
EN 55014-2:1997/A2:2008
EN 61000-3-2:2014
EN 61000-3-3:2013

2000/14/EC_2005/88/EC Annex VI

For model KS 7THE 52/30, KS 8TKE 52/35 noise guaranteed $L_{WA} = 97$ dB (A).



19

Issued Date: 2020-10-06
Place of issue: Warsaw city
Technical expert: Homenco A.

DIMAX
International
GmbH

Steuer-Nr.: 103 5722 2493
USt-Id-Nr.: DE296177274

We DIMAX INTERNATIONAL GmbH hereby declare that specified above conforms covering European Parliament and Council Directives, 2006/42/EC of 17 May 2006 Machinery Directive, 2014/35/EC Low Voltage Directive of 26 February 2014, Electromagnetic compatibility Directive (EMC) 2014/30/EC of 26 February 2014, Noise Directive 2000/14/EC of 8 May 2000. The CE mark above can be used under the responsibility of manufacturer. After completion of an EC declaration of Conformity and compliance with all relevant EC directives.

CONTACTS

Deutschland:

DIMAX International GmbH
Deutschland, Hauptstr. 134,
51143 Köln,

www.ks-power.de

Ihre Bestellungen

orders@dimaxgroup.de

Kundendienst, technische Fragen und Unterstützung

support@dimaxgroup.de

Garantie, Reparatur und Service

service@dimaxgroup.de

Sonstiges

info@dimaxgroup.de

Polska:

DIMAX International
Poland Sp.z o.o.

Polen, Warczawska, 306B
05-082 Stare Babice,

www.ks-power.pl
info.pl@dimaxgroup.de

Україна:

ТОВ «Техно Трейд КС», вул.
Електротехнічна 47, 02222,
м. Київ, Україна

www.ks-power.com.ua
sales@ks-power.com.ua

Россия:

ТД «Рус Энержи К&С» 129090,
г.Москва, проспект Мира,
д.19, стр.1, эт.1, пом.1,
комн.66, офис 99В

www.ks-power.ru
info@ks-power.ru